



SOLAR MODULE REC A-SERIES

DATASHEET

REC205A
REC210A
REC215A
REC220A
REC225A
REC230A

UNCOMPROMISING QUALITY

The REC A-Series is a high quality series of solar modules designed to meet system demand for exceptional performance. Rigorous quality control is applied throughout the production process, from cells to modules. The multicrystalline solar cells within each module are optimized for low light conditions and increased light absorption. The modules have an innovative design that eliminates shading effects in order to achieve maximum performance. A power output tolerance of 5 % guarantees minimum mismatch losses.

QUICK INSTALLATION

The comparatively low weight (22 kg) of the REC A-Series allows for quick and easy installation. The modules are equipped with MC FlexSol solar cables, with MC III connectors for problem-free inter-module connection.

ENVIRONMENTALLY SOUND PRODUCTS & PROCESSES

The REC A-Series series generate environmentally sound electricity. Our cell and module production processes are designed to maximize recycling and reduce environmental impact. REC's wafers, cells and modules are produced within Scandinavia and our activities are therefore subject to very high standards of regulation regarding environmental issues.

CUSTOMER SATISFACTION GUARANTEE

The REC A-Series comes with a guarantee of 90% of rated power output for 10 years, and 80% of rated power output for 25 years.

Further warranty information is available upon request.

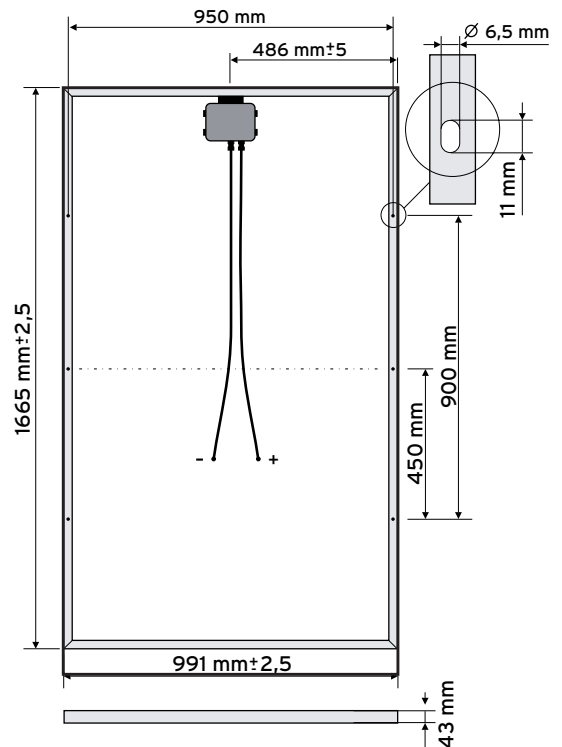
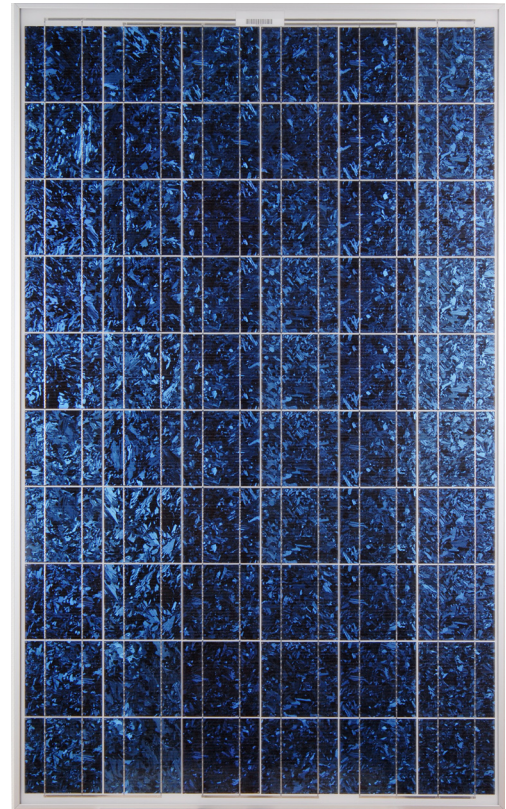

MODULE TYPE

A-SERIE

MODEL	REC205A	REC210A	REC215A	REC220A	REC225A	REC230A
ELECTRICAL DATA						
Nominal Power P _{mpp} (Wp)	205	210	215	220	225	230
Power Output Tolerance P _{mpp} (%)	±5	±5	±5	±5	±5	±5
Maximum Power Voltage V _{mpp} (V)	28.1	28.2	28.3	28.7	29.1	29.4
Maximum Power Current I _{mpp} (A)	7.3	7.5	7.6	7.7	7.7	7.8
Open Circuit Voltage V _{oc} (V)	36.1	36.1	36.3	36.6	36.8	37.1
Short Circuit Current I _{sc} (A)	7.9	8.1	8.1	8.2	8.2	8.3
Temperature Coefficient of P _{mpp} (%/°C)	-0.452	-0.452	-0.452	-0.452	-0.452	-0.452
Temperature Coefficient of V _{oc} (%/°C)	-0.34	-0.34	-0.34	-0.34	-0.34	-0.34
Temperature Coefficient of I _{sc} (%/°C)	0.074	0.074	0.074	0.074	0.074	0.074
Module Efficiency (%)	12.4	12.7	13.0	13.3	13.6	13.9
Max Series Fuse Rating (A)	15	15	15	15	15	15

Values at Standard Test Conditions STC (Air Mass AM 1.5, Irradiance 1000 W/m², Cell temperature 25 °C)

NOCT (Nominal Operating Cell Temperature) 43°C ±2

The NOCT values are reached at an irradiance of 800 W/m², at an ambient temperature of 68 °F [20 °C] and a wind speed of 1 m/s.

Performance measurements at different low irradiance levels: 800 W/m² = - 19.6%, 500 W/m² = - 49.8%, 200 W/m² = - 80.6%.

SIZE AND WEIGHT

AE-SERIES

Area (m ²)	1.65
Length (mm)	1665
Width (mm)	991
Thickness with frame (mm)	43
Weight (kg)	22

OPERATION LIMITS

Maximum System Voltage:	1000 V
Module temperature range:	- 40... + 80 °C
Maximum load:	551 kg/m ² (5400 Pa)
Storm proof:	wind speed of up to 197 km/h and security factor 3.

GENERAL**Cells**

Multi-crystalline cells: 156 mm x 156 mm, 60 in series

Module

Front:	High-transparency solar glass with antireflection surface treatment.
Encapsulation:	EVA
Backsheet:	TPT
Junction box:	Easy access, 3 x 12A bypass diodes.
Frame:	Anodized aluminum.

Connection

2 x 0.94 m solar cables with MC III connectors.

**CERTIFICATION / STANDARDS**

Complies to IEC 61215 2. edition and TÜV Safety Class II

Note: Specifications subject to change without notice.



For further information contact your local distributor or visit our web site:

www.recgroup.com